

Variations:

| Max length: | | Voltage input: | |
|-------------|-----|----------------|--------|
| L1 | L2 | 12 V | 24 V |
| 28 | 78 | 531013 | 531014 |
| 53 | 103 | 531023 | 531024 |
| 78 | 128 | 531033 | 531034 |

| Current diagram: | 12 V | 24 V |
|------------------|--------|--------|
| No load | < 6 A | < 3 A |
| Normal running | < 10 A | < 5 A |
| Stall | < 40 A | < 20 A |
| Fuse | 40 A | 20 A |

Limited warranty

- Roca warrants the wiper motors to be free from defective material and workmanship for a period of 3 years from the date of purchase.
- This warranty does not apply to failure or damage caused by improper installation, misuse, lightning strike or damage from a power surge.
- If failure occurs during this period, return it to your dealer for repair or replacement.

Wiper arms and blades:

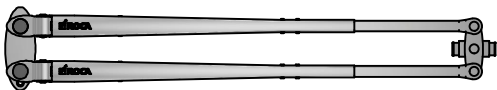

Pantograph
536430 / 536335 EP
538430 / 538335 Black

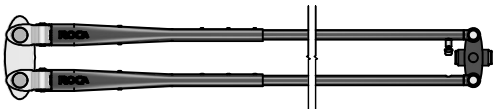

Pantograph
536347 EP
538347 Black



Blade (28"- 40")
520828 - 40

241015/LW

WIPER MOTOR | W50

Installation Instructions

Before installation please read these instructions.

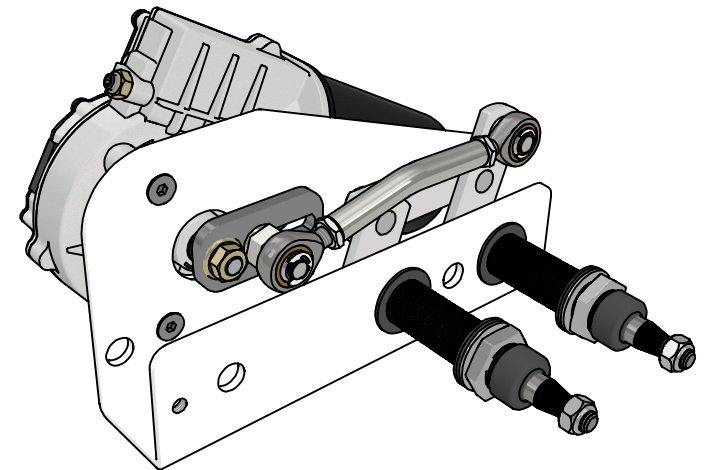

- 2 Speed, self-parking (30/47 Sweep/min)
- Torque 50 Nm
- Wipershaft in stainless steel
- Various sweep angle: 45 - 110°
- Dynamic park circuit
- Internal thermoswitch
- Insulated ground
- EMC protected
- Powers up to 1100 mm/1100 mm Arm/blade combinations



Instructions - Adjusting the sweep angle and parking position

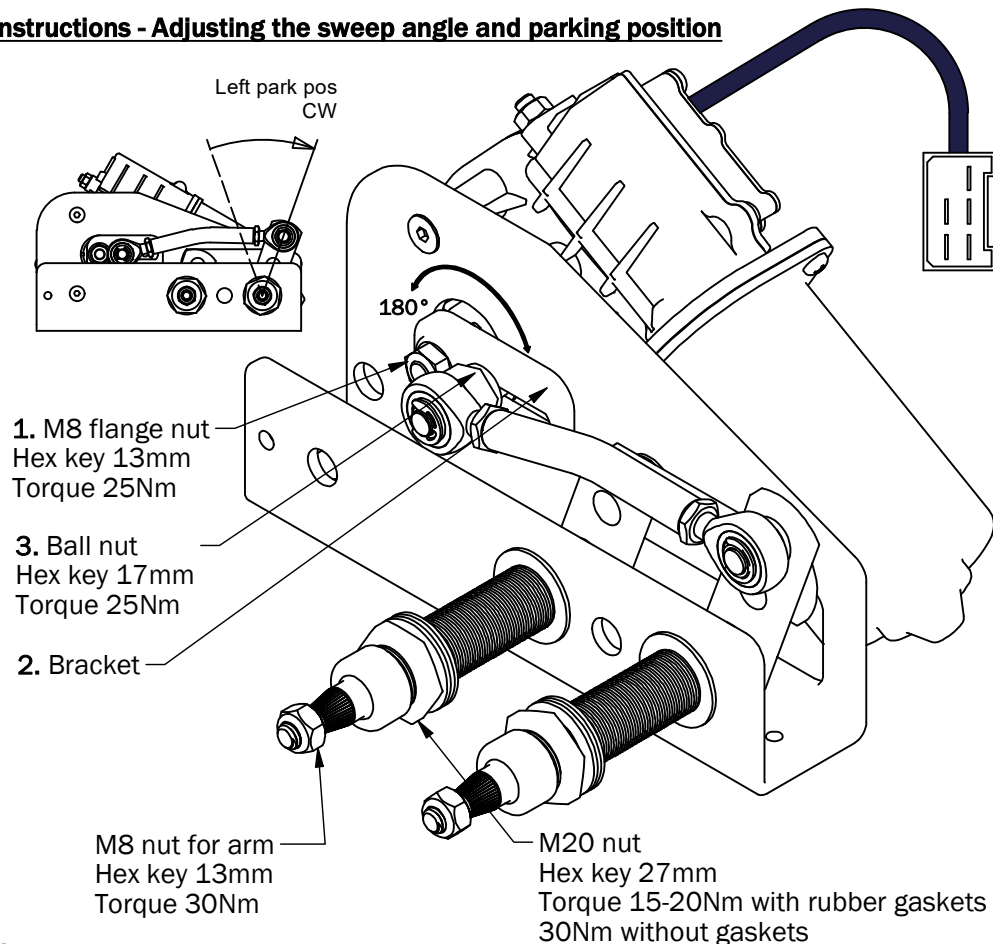

Changing the parking position.

Before the parking position is changed, make sure that the wiper motor is in its parked position (Default is to the left). This is easiest done by turning on and off the power to the wiper motor. For safety, turn off and keep the battery main switch turned off during any operation inside of the wiper motor.

- Loosen the nut (1).
- Snap off the bracket from the shaft on the motor (2).
- Rotate the bracket 180°.
- Assemble the bracket and tighten the nut firmly.

Change of wiped angle.

The sweep angle can be set at any point between 45° and 110°. (Default is 45°). Before you change the sweep angle, make sure that the wiper motor is in its parked position. This is easiest done by turning on and off the power to the wiper motor. For safety, turn off and keep the battery main switch turned off during any operation inside of the wiper motor.

- Loosen the nut (3).
- Move the nut (3) to desired position in the slot by changing the position of the wiper arm.
- Tighten the nut (3) firmly.

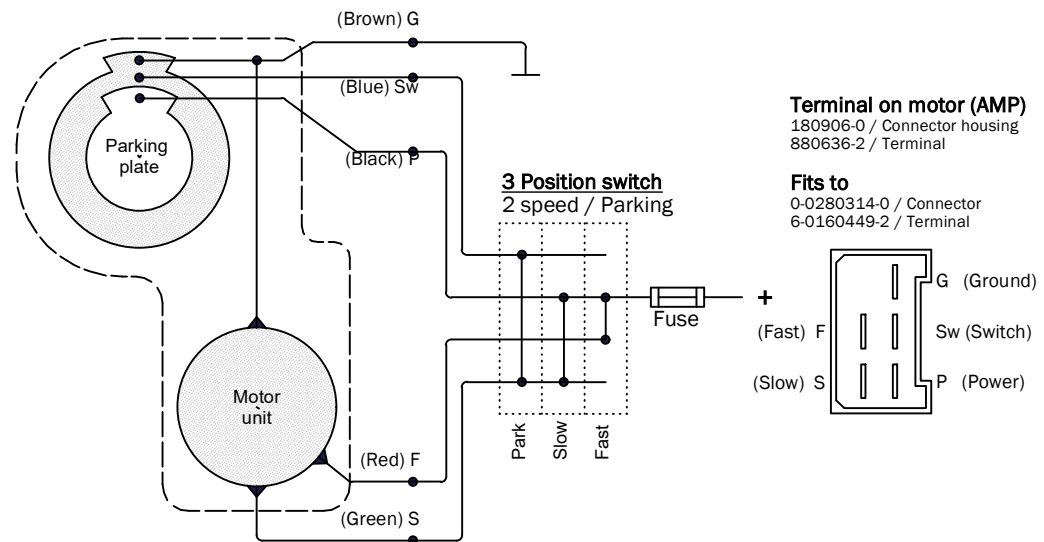

Alt. 1 (3 pos.switch)

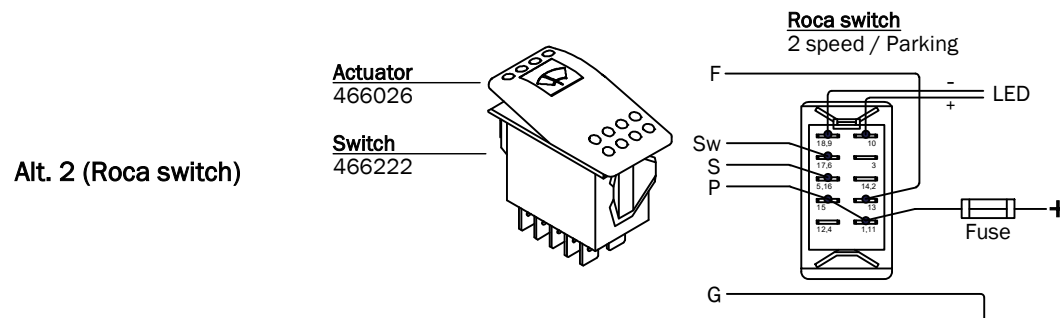

Alt. 2 (Roca switch)

Alt. 3 (Alternative switch)

